

Write your homework questions on the board and start the questions below... Grab a textbook

$$11 - 4(2)$$

$$11 - 8 = \boxed{3}$$

#1.



$$VM = MW$$

$$30 = x + 10$$

$$\begin{array}{r} 30 = x + 10 \\ -10 \quad -10 \\ \hline 20 = x \end{array}$$

$$x = \underline{20}$$

#2.

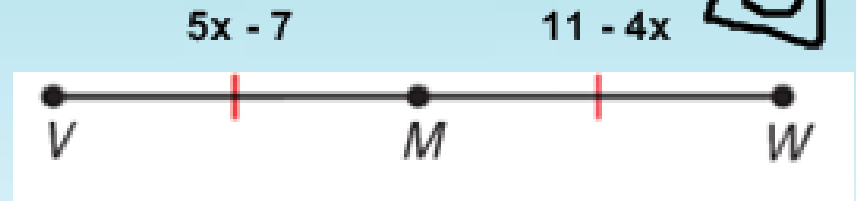

$$VM = MW$$

$$5x - 7 = 11 - 4x$$

$$\begin{array}{r} 5x - 7 = 11 - 4x \\ +7 \quad +7 \\ \hline 5x = 18 - 4x \\ +4x \quad +4x \\ \hline 9x = 18 \\ MW = \underline{3} \end{array}$$

$$\boxed{x = 2}$$

# Homework questions.?

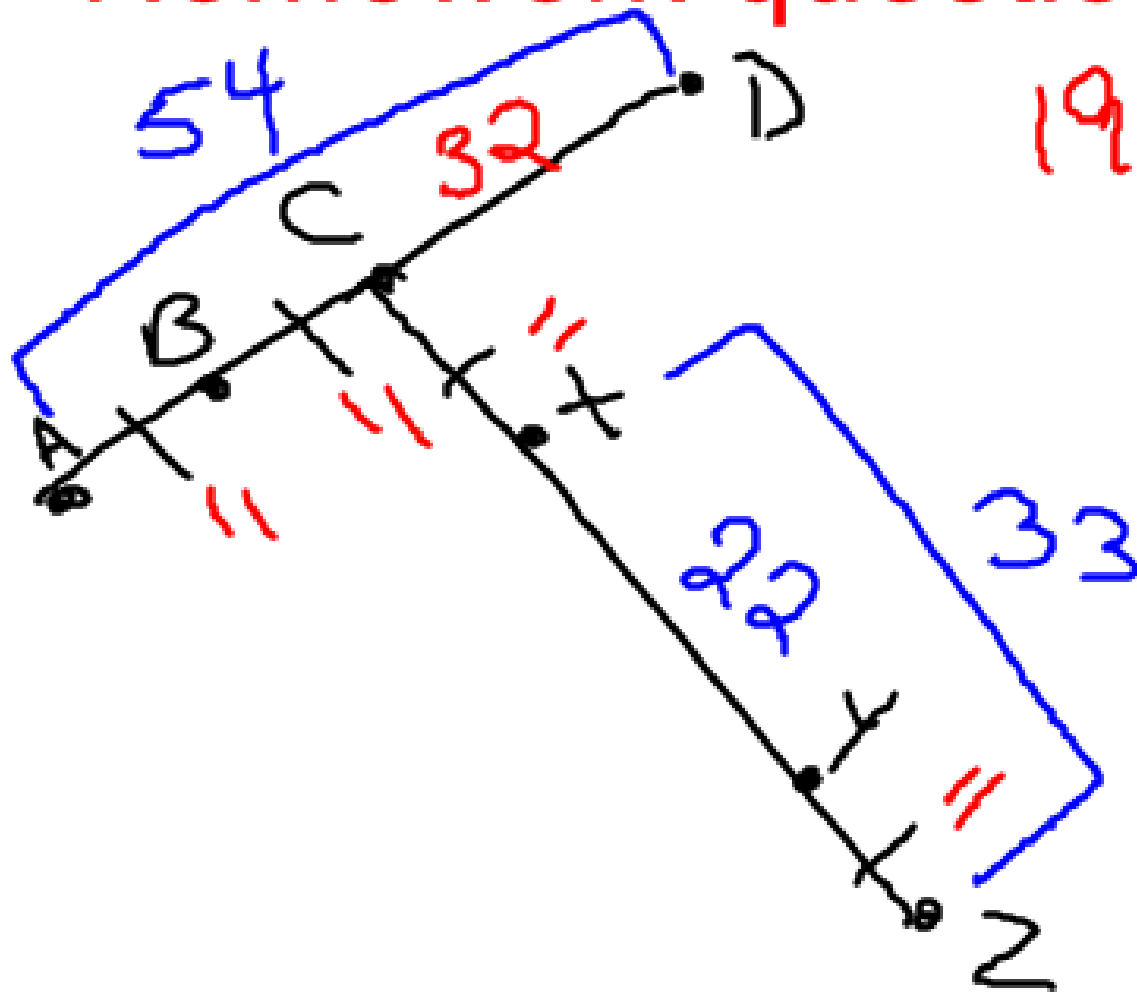

19-24

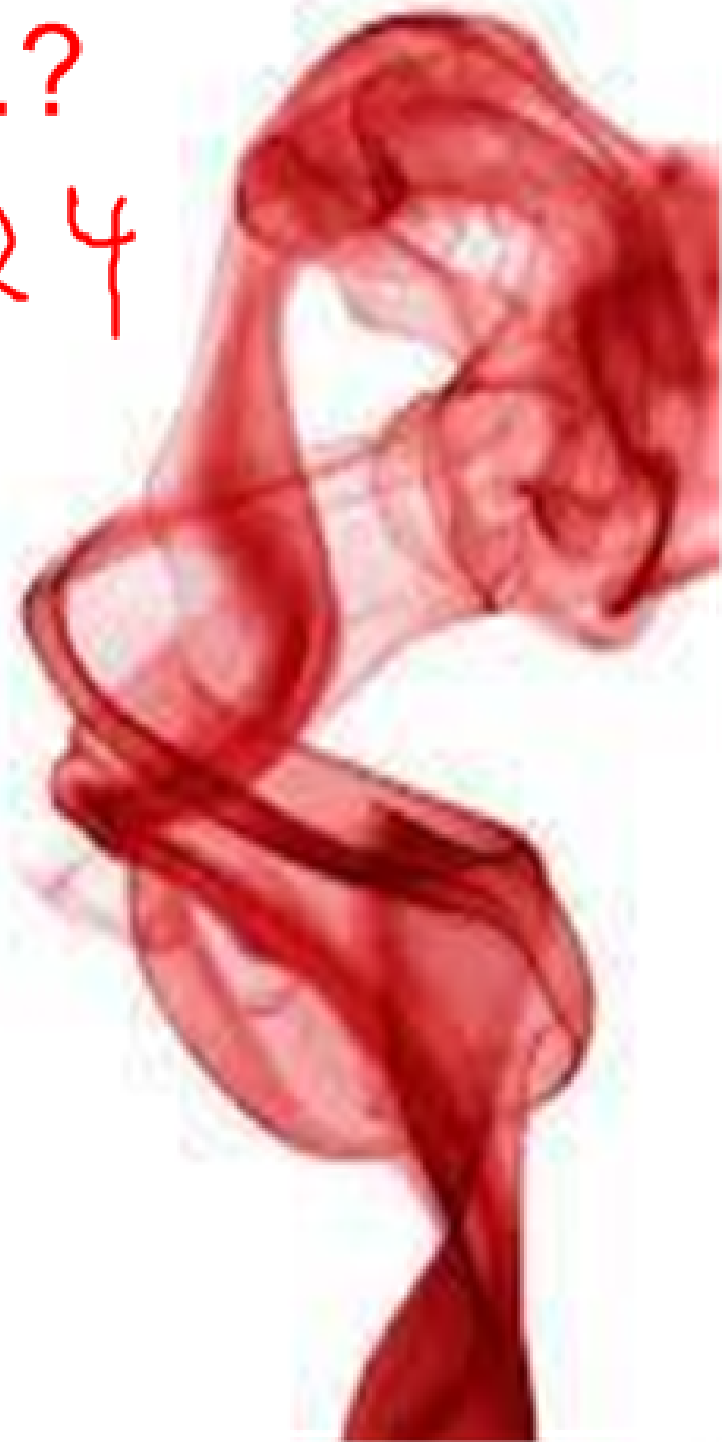

26)

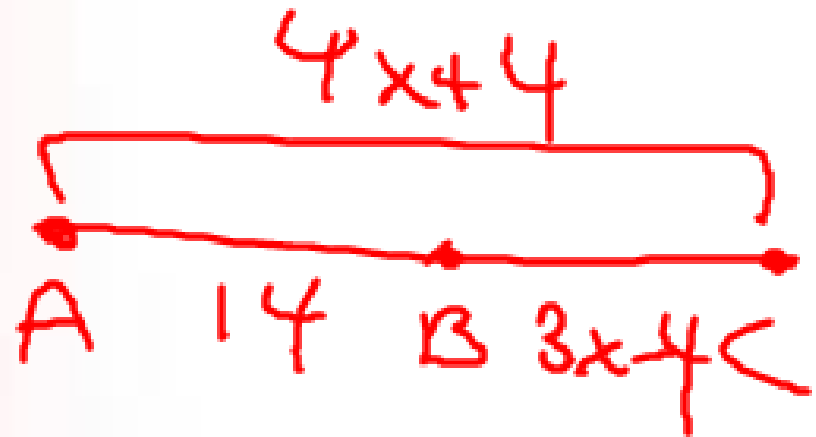

$$AB + BC = AC$$

$$\underline{14} + 3x - 4 = 4x + 4$$

$$10 + \cancel{3x} = 4x + 4$$

$$-3x - 3x$$

$$\hline 10 = 1x + 4$$

$$-4$$

$$\cancel{-4}$$

$$\hline 6 = x$$

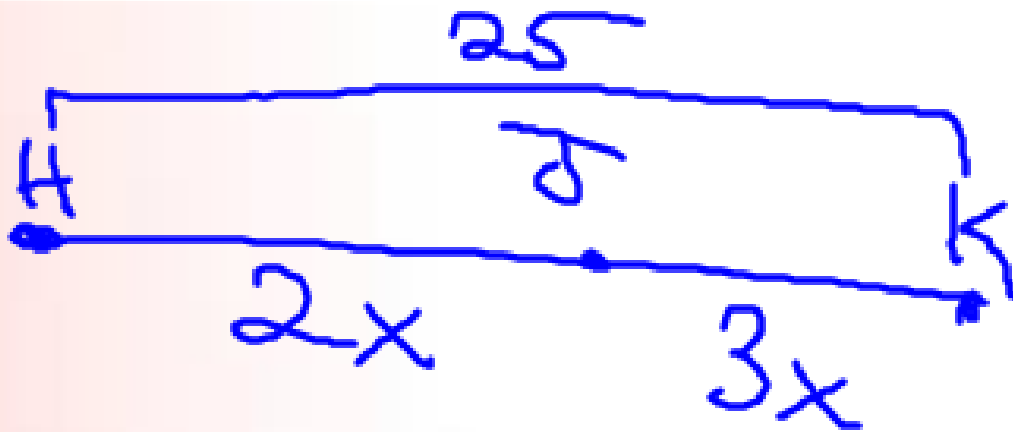

$$HJ + JK = HK$$

$$2x + 3x = 25$$

$$5x = 25$$

$$x = 5$$

# Homework...?

Geometry

Sections 1.1-1.2

Name: \_\_\_\_\_

Use the diagram to decide whether the given statement is *true* or *false*.

- Points  $H$ ,  $I$ , and  $G$  are collinear. *True*
- Points  $H$ ,  $I$ , and  $J$  are coplanar. *True*
- $\overrightarrow{EG}$  and  $\overrightarrow{FG}$  are opposite rays. *True* 
- All points on  $\overrightarrow{GI}$  and  $\overrightarrow{GF}$  are coplanar. *True*
- The intersection of  $\overrightarrow{EF}$  and plane  $JKH$  is  $\overline{HI}$ . *False*  
*It is G.*
- The intersection of  $\overrightarrow{EF}$ ,  $\overline{HI}$ , and  $\overline{JG}$  is point  $G$ . *True*
- The intersection of plane  $EGH$  and plane  $JGI$  is point  $G$ . *False*  
*It is HI*
- The intersection of plane  $EFI$  and plane  $JKG$  is  $\overline{HG}$ . *True*

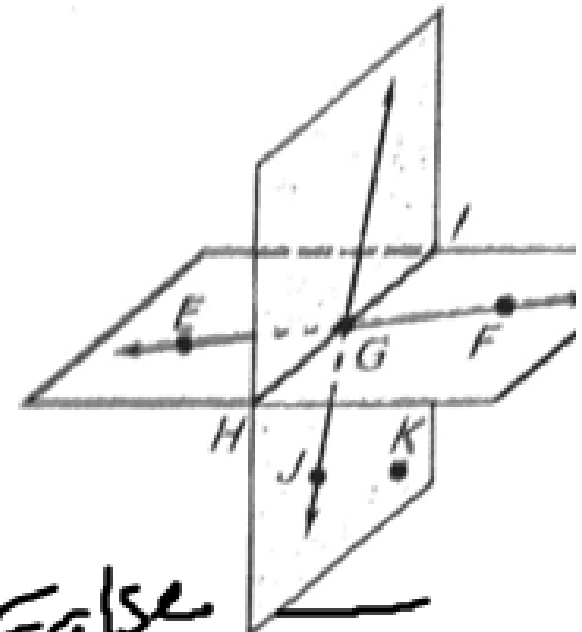

*False*  
*It is HI*

Measure the length of the segment to the nearest tenth of a centimeter.

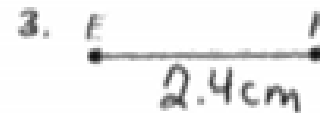
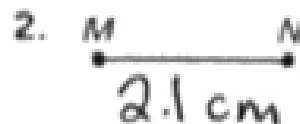

Use the Segment Addition Postulate to find the indicated length.

4. Find  $RT$ .



$$RS + ST = RT$$

$$17 + 8.5 =$$

$$\boxed{= 25.5}$$

5. Find  $BC$ .



$$AB + BC = AC$$

$$25 + x = 54$$

$$\boxed{x = 29}$$

6. Find  $MN$ .

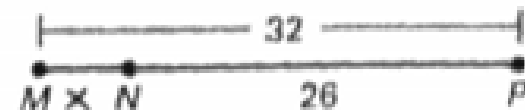

$$MN + NP = MP$$

$$x + 26 = 32$$

$$\boxed{x = 6}$$

In the diagram, points  $A, B, C,$  and  $D$  are collinear, points  $C, X, Y,$  and  $Z$  are collinear,  $AB = BC = CX = YZ$ ,  $AD = 54$ ,  $XY = 22$ , and  $XZ = 33$ . Find the indicated length.

19.  $AB = 11$

20.  $BD = 43$

21.  $CY = 33$

22.  $CD = 32$

23.  $XC = 11$

24.  $CZ = 44$

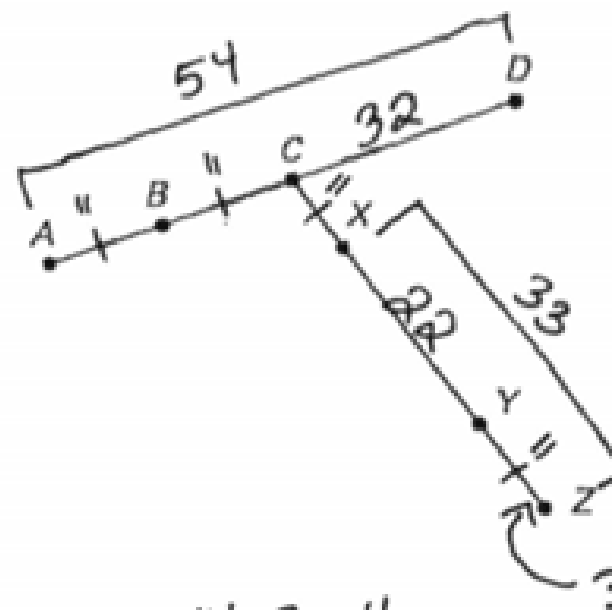

Find the indicated length

Find the indicated length.

25. Find  $ST$ . =  $\frac{12(2)}{\boxed{24}}$

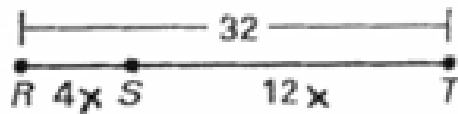

$$4x + 12x = 32$$

$$16x = 32$$

$$x = 2$$

Point  $J$  is between  $H$  and  $K$  on  $\overline{HK}$ . Use the given information to write an equation in terms of  $x$ . Solve the equation. Then find  $HJ$  and  $JK$ .

28.  $HJ = 2x$   
 $JK = 3x$   
 $KH = 25$



$$2x + 3x = 25$$

$$5x = 25$$

$$x = 5$$

$$HJ = 2x$$

$$= 2(5)$$

$$= \boxed{10}$$

$$JK = 3x$$

$$3(5) = \boxed{15}$$

26. Find  $AC$ . =  $\frac{14 + 3x - 4}{3(6) + 10} = \boxed{28}$

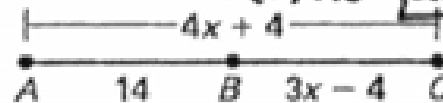

$$14 + 3x - 4 = 4x + 4$$

$$3x + 10 = 4x + 4$$

$$6 = x$$

27. Find  $NP$ . =  $\frac{3x + 2}{3(10) + 2} = \boxed{32}$



$$x - 5 + 3x + 2 = 6x - 23$$

$$4x - 3 = 6x - 23$$

$$20 = 2x$$

$$x = 10$$

29.  $HJ = \frac{x}{4}$   
 $JK = 3x - 4$   
 $KH = 22$

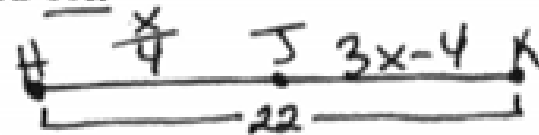

$$HJ = \frac{x}{4}$$

$$\frac{8}{4} = \boxed{2}$$

$$\frac{x}{4} + 3x - 4 = 22$$

$$.25x + 3x - 4 = 22$$

$$3.25x - 4 = 22$$

$$3.25x = 26$$

$$JK = 3x - 4$$

$$3(8) - 4$$

$$24 - 4 = \boxed{20}$$

$$x = 8$$



**Section 1.3**

**Midpoint Formula**



# Homework Assignment

Pg.19

#5, 11, 17, 18, 25, 26



# Finding the Midpoint of a Segment

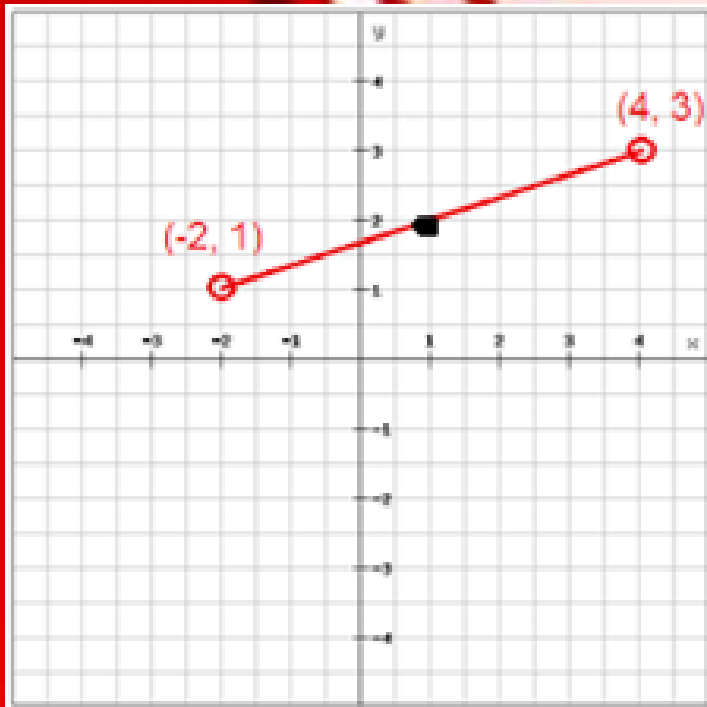

## Mid-point Formula

$$\left( \frac{x_1 + x_2}{2}, \frac{y_1 + y_2}{2} \right)$$

$$\left( \frac{-2 + 4}{2}, \frac{1 + 3}{2} \right)$$

$$M(1, 2)$$

$$\begin{matrix} x_1, y_1 \\ (2, 1) \\ x_2, y_2 \\ (4, 3) \end{matrix}$$

## examples...

### Mid-point Formula

$$\left( \frac{x_1 + x_2}{2}, \frac{y_1 + y_2}{2} \right)$$

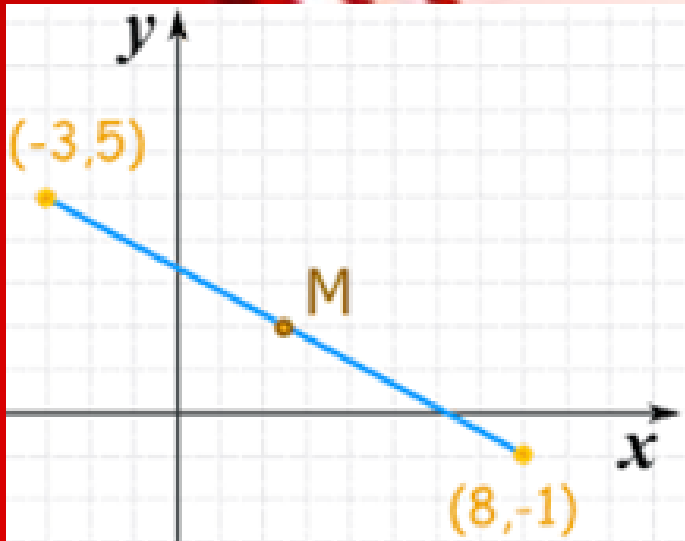

$$\begin{matrix} x_1 & y_1 \\ (-3, & 5) \end{matrix}$$

$$\begin{matrix} x_2 & y_2 \\ (8, & -1) \end{matrix}$$

$$\left( \frac{-3+8}{2}, \frac{5+(-1)}{2} \right)$$

$$M \left( \frac{5}{2}, 2 \right)$$

1.



examples...

Try on your own

**Mid-point Formula**

$$\left( \frac{x_1 + x_2}{2}, \frac{y_1 + y_2}{2} \right)$$

$$\left( \frac{-1 + 3}{2}, \frac{3 + (-4)}{2} \right)$$

$$M\left(1, -\frac{1}{2}\right)$$

2.  $(-4, 5)(2, -3)$

3.  $(-3, 5)(8, -1)$

# Mid-point Formula Finding the Endpoint given a Mdpt and Endpt

$$\left( \frac{x_1 + x_2}{2}, \frac{y_1 + y_2}{2} \right)$$

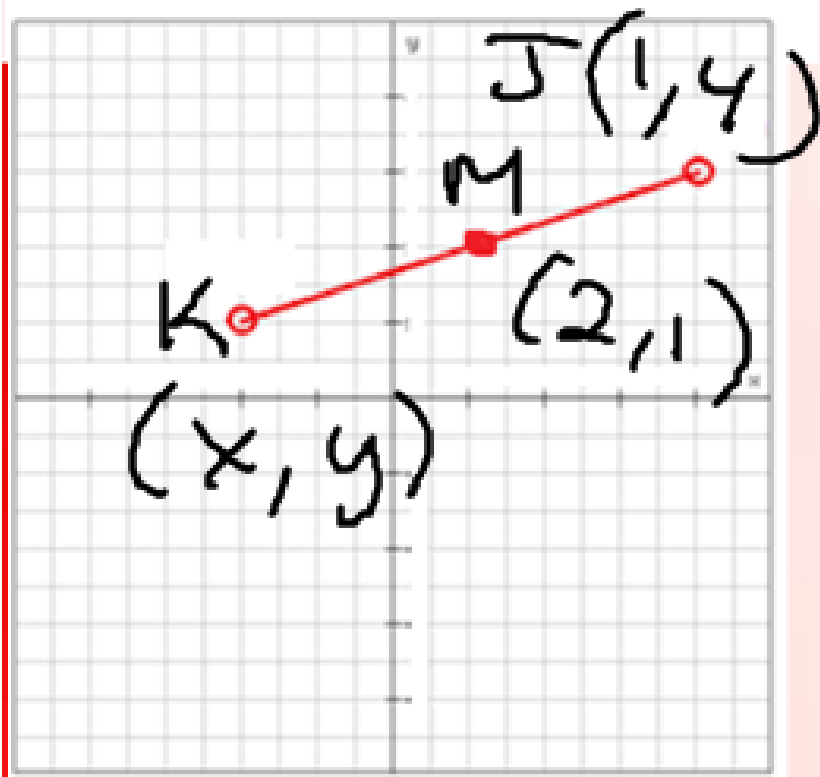

$$\frac{x + x}{2} = x, \quad \frac{y + y}{2} = y$$

$$\textcircled{2} \quad \frac{1 + x}{2} = 2, \quad \frac{4 + y}{2} = 1$$

$$\begin{array}{r} x + x = 4 \\ -1 \quad -1 \\ \hline x = 3 \end{array}$$

# Mid-point Formula Finding the Endpoint given a Mdpt and Endpt

$$\left( \frac{x_1 + x_2}{2}, \frac{y_1 + y_2}{2} \right)$$

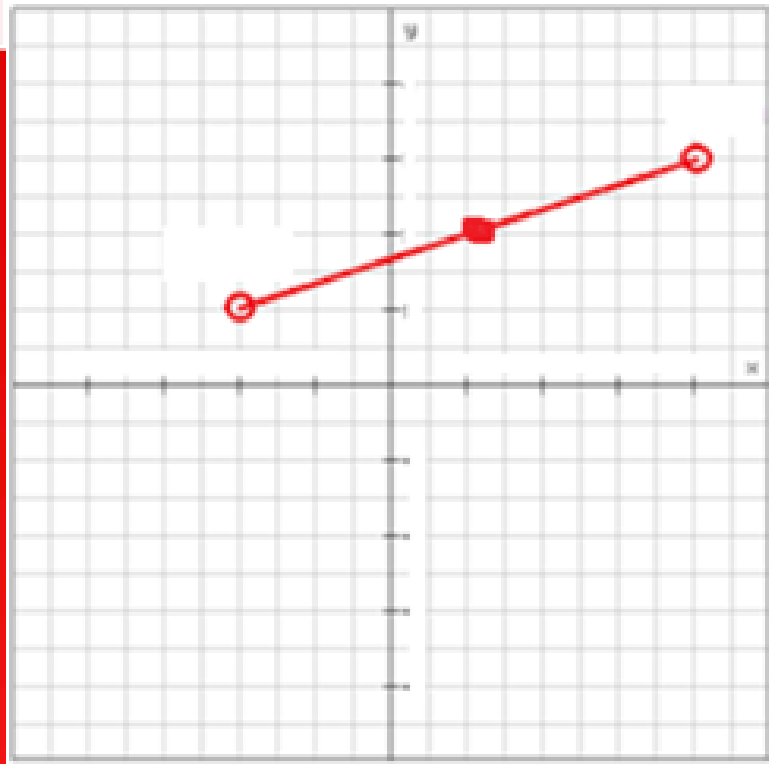

## Try On your Own

**Pg. 896**  
**# 24 - 26**

### **Mid-point Formula**

$$\left( \frac{x_1 + x_2}{2}, \frac{y_1 + y_2}{2} \right)$$

# Homework Assignment

Pg.19

#5, 11, 17, 18, 25, 26

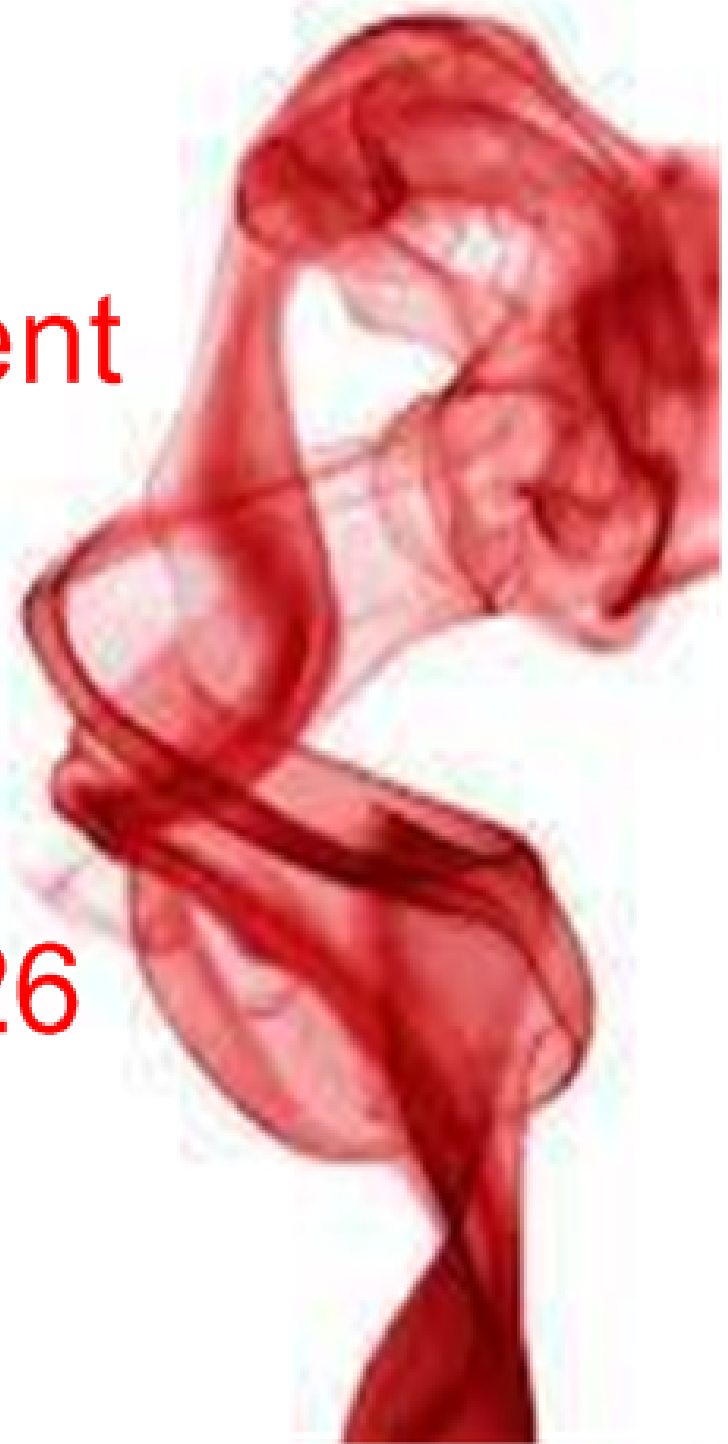



Homework...?



# Finding the Distance from one point to another

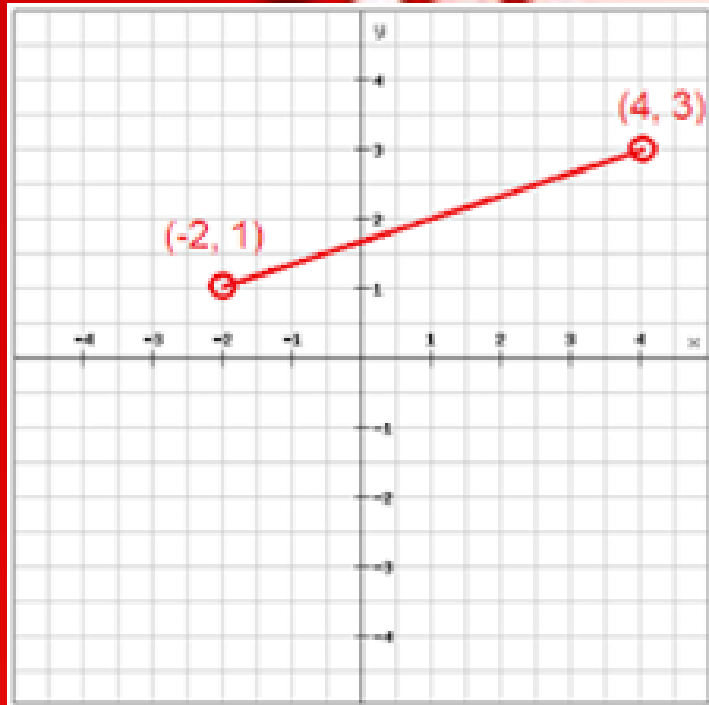

**Distance Formula**

$$\sqrt{(x_2 - x_1)^2 + (y_2 - y_1)^2}$$

## examples...

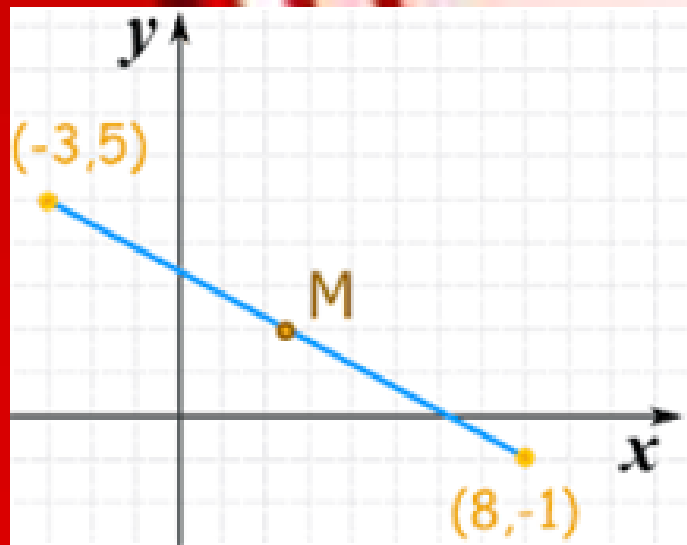

### Distance Formula

$$\sqrt{(x_2 - x_1)^2 + (y_2 - y_1)^2}$$

1.



examples...

Try on your own

Distance Formula

$$\sqrt{(x_2 - x_1)^2 + (y_2 - y_1)^2}$$

2.  $(-4, 5)(2, -3)$

3.  $(-3, 5)(8, -1)$

# Homework Assignment

Pg.19

#3, 5, 6, 11, 13, 14, 17,  
18, 19, 31, 32, 33

